

Cheetah™ DOCSIS®-based Transponder for Cable Power Systems

Tollgrade's CMD-P transponder enables cable operators to pro-actively monitor power systems in the outside cable plant using the existing DOCSIS infrastructure. Power system data is sent via the DOCSIS channels from the transponder through the existing CMTS to SNMP software managers such as Tollgrade's CheetahXD™. With the Cheetah hardware and software solution, cable operators are able to pro-actively respond to plant performance issues, minimizing plant downtime, lowering costs and protecting the revenue stream generated by advanced services.

The CMD-P has been designed to monitor a wide range of power supply equipment from multiple manufacturers, including:

- Alpha CPR
- Alpha USM series for the XM / XM2
- Lectro ZTT and ZTT+
- Multipower Blackhawk
- HMS-enabled Power Supplies

Please see your Tollgrade representative for a complete listing.

By using the existing DOCSIS infrastructure and frequencies, Cheetah CMD-P transponders can be easily and cost-effectively deployed within the cable network.

The CMD-P can also be optionally enabled as an E-MTA to perform an advanced suite of IP and VoIP tests, thus turning it into a true cross-domain test point combining the measurements available from the HFC, DOCSIS, IP and VoIP domains.

Features

- Uses the existing DOCSIS infrastructure;
- Is ANSI/SCTE-HMS standards-compatible;
- Requires no dedicated frequencies;
- Can be optionally field-upgraded for IP and/or VoIP testing;
- Supports downloadable firmware for new features and applications; and
- Features a low-voltage disconnect to protect batteries in the event of deep discharge events.



Cheetah DOCSIS-based transponders provide unparalleled visibility into the HFC network and can be upgraded to be advanced VoIP test points.

Bi-directional HFC Network

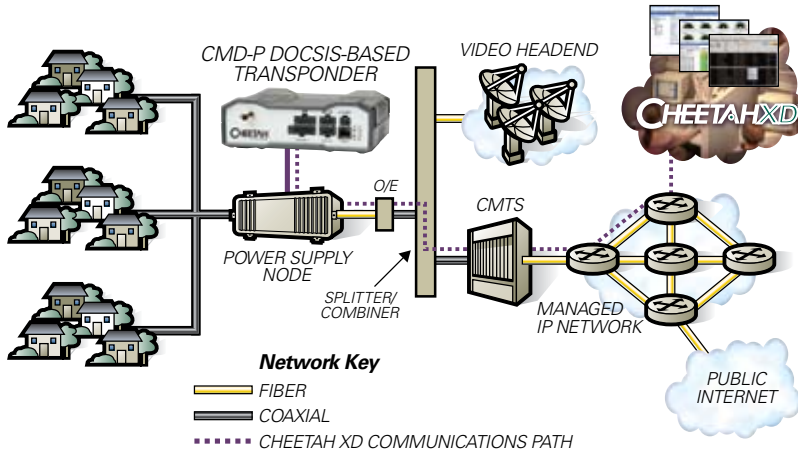

An Optimal End-to-end Design

From the full-featured CheetahXD Software to the CMD-P DOCSIS-based, HMS Transponder MIB Extensions, Tollgrade provides a status monitoring solution designed to grow as your HFC status monitoring needs evolve.

Cheetah Family

Designed for environmental extremes experienced by the outside plant, the Cheetah CMD-P DOCSIS-based transponder uses hardened versions of the same reliable DOCSIS-based technologies that are used in millions of modems.

A value-added feature allows the Cheetah CMD-P transponder to disconnect itself from battery power when voltages get too low during deep discharge events, preventing damage to the batteries. When power is restored, the transponder will return to normal operation.

When combined with the powerful analysis tools built into Tollgrade's CheetahXD Broadband Assurance Platform, the Cheetah DOCSIS-based transponder provides an effective early-detection system that allows operators to be proactive with system maintenance, helping to preserve the revenue of today's advanced services.

CMD-P Specifications

General

Devices MonitoredPower supplies, batteries, generators reported as per ANSI/SCTE 25-3 2002 (HMS-022)
 DOCSISVersion 2.0
 DOCSIS Monitoring ProtocolSNMP v1, v2, v3
 HMS Monitoring ProtocolSNMP v1, v2c
 RF Cable InterfaceF-connector, Female, 75 ohm impedance
 Local/Craft InterfaceRJ-12, RS-232, 19.2kb, N, 8, 1
Required: Adapter to connect to PC serial port, Hypertextual or equivalent)
 Operating Temperature-40°C to +75°C
 Humidity10% to 90% (non-condensing)
 EMI/EMCFCC Part 15 Class A, CE EN50022 Class A

RF Transmit/Receive

Tx Frequency Range5 to 42 MHz
 Tx Output Power+8 to +58 dBmV
 Rx Frequency Range91 to 857 MHz
 (Center frequency of Standard, HRC, IRC)
 Rx Input Level-15 to +15 dBmV
 Channel Bandwidth6 MHz

Management

NMS/EMSCheetahXD Software/Standard SNMP Management Tools
 MIBs SupportedANSI/SCTE 25-3 2002 (restricted by device monitored), DOCSIS 1.1

Parametric Measurements, Inputs/Outputs, Mechanical/Power

Detailed technical specification sheets are available for each target device that has been integrated. Please contact your Tollgrade representative for more information.

Ordering Information

Please contact your Tollgrade representative for ordering information.



Corporate Headquarters
 493 Nixon Rd
 Cheswick, PA 15024 USA
 +1 412 820 1400 | 1 800 878 3399
 www.tollgrade.com

© Tollgrade is a registered trademarks of Tollgrade Communications, Inc.
 © DOCSIS is a registered trademark of Cable Television Laboratories, Inc. (CableLabs®)
 © 2008 Tollgrade Communications, Inc. All rights reserved. Specifications and features are subject to change without notice.
 (06-08)